



TR 9650

Mobile bath Lift System

Hygiene Equipment
Designed for People

TR 9650 Designed for Maximum Flexibility

The TR 9650 is a Mobile Bath Lift System is designed to easily convert into different configurations to accommodate a wide variety of needs for patients and residents in both the acute and long term care environments.



Registered at Medical Products Agency, Sweden, as a MD Class 1 product, MDD 93/42EEC.

TR reserves the right to make design changes and/or improvements without notice.



Whether in a standing, seated or recumbent position the TR 9650 provides a dignified complete solution for residents needing aid getting in and out of bathtubs. Easy access and comfortable padded seating surfaces ensure a pleasant bathing experience. Ergonomically designed hand grips and safety belts are incorporated into the TR 9650 to provide the security and assurance for both the attendant and the resident being bathed. The TR 9650 can be converted between a chair bath lift and a stretcher configurations, so individual patient bathing and lifting needs can be addressed efficiently by the staff/caregiver.



TR EQUIPMENT

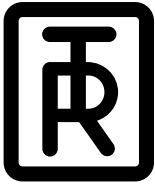

TR 9650

Mobile bath Lift System

Hygiene Equipment
Designed for People

Features

- Foot operated and height adjustable enables the attendant to find the most efficient and convenient working height and gives the attendant both hands free to tend to the patient.
- Seating and stretcher surfaces made of a soft, durable water absorbent material which makes it easy to clean, maintain and is very comfortable to sit and lay on.
- Removable side parts provide a simple configuration from chair to stretcher.
- The safety arm support in both the chair and stretcher configurations can be folded away for easy access and moved back once the resident is in position.
- The leg configuration is designed for easy approach onto the chair and stretcher.
- A low chassis is designed for easy access under beds and baths.
- A safety stop engages automatically if the chair or stretcher is lowered onto any surfaces or obstacles.
- An integral autostop ensures that the seat and stretcher cannot drop should the belt fail.
- Magnetic battery charger connection designed to prevent damage when charging.
- Audible low battery tone.
- Ready for use after unpacking and comes complete with battery charger and safety belts.
- TR 9650 can be used together with almost all supine bath tubs and therapy. An optional spacer can be purchased for changing or improving the location of the bath lift into the tub.
- Additional features include foot activated emergency stop, high capacity rechargeable batteries and both locking and straight steering large castors.
- Easy access and comfortable padded seating surfaces ensure a pleasant bathing experience.



Commode seat on chair can be converted to smooth seat with lid placement.

Comfortable and easy to clean laying and seating surfaces.

Narrow chassis design for easy and safe transfers.



Comfortable back rest that can easily be moved to either arms for back support.

Attachable stretcher side parts for easy conversion from stretcher to chair. No tools required.

Emergency stop button and magnetic battery charger connection for safety and ease of use.

Application Examples

Together with the TR Bathtubs the Mobile Bath Lift System completes a system that offers a safe, labour efficient, person oriented bathing cycle with increased care quality.



Specifications

Operating Height Range	200 - 965 mm (8 - 38")
Working Load Limit	150 kg (330 lbs)
Structure	Powder coated, zinc plated steel and stainless steel
Castors	Twin Ø100 mm (4") castors, two with brakes and two with straight steering
Control	Foot control for height adjustment
Stretcher, Pillow	Flame retardant material
Battery	Rechargeable, 24 V

Models

- Chairlift. Art.no. 0542000 incl. battery charger
- Stretcherlift. Art.no. 0542010 incl. battery charger
- Combilift with chair. Art.no. 0542020 incl. battery charger
- Two Stretcher side parts for combilift with chair incl. pillow. Art.no. 0542030

Option

- TR Scale 1650

Accessories

- Extension adapter to increase distance from lift column to chair/stretcher (60 mm)

Dimensions (mm)

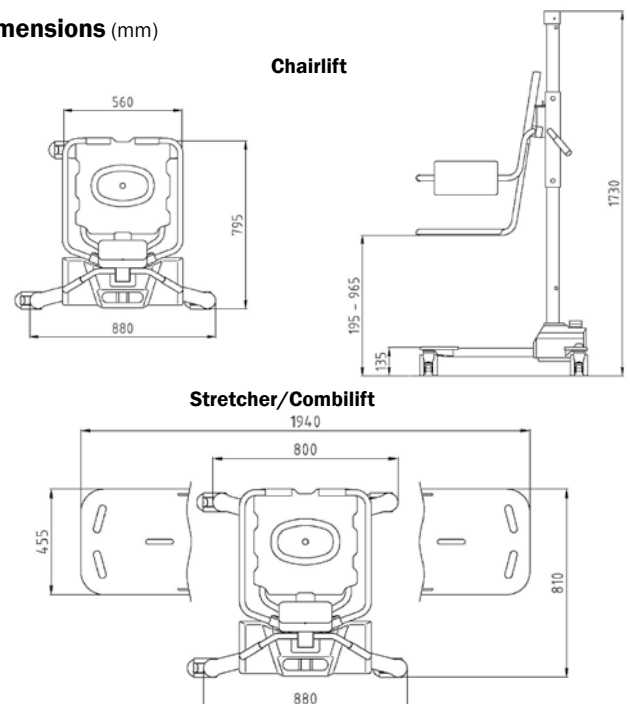

Head office

TR Equipment AB, Sweden
Phone: +46 140 38 50 60
info@trequipment.se
www.trequipment.com

Group Subsidiaries

TR Group Inc, US, Phone: +1 (800) 752 6900
TR Equipment Ltd, UK, Phone: +44 (0) 844 335 8386
TRanspoRehaMed GmbH, Germany, Phone: +49 (0) 212 645850-0



TR EQUIPMENT